

# WIM EDUCATION FOUNDATION



## MINERALS ACTIVITY BOOKLET

Mineral resources and their production have contributed greatly to the development of America. Our country contains the vital metals and fossil fuels needed to build homes, industry and to generate power. Machines, synthetics, building materials, fertilizers and numerous alloys contribute to the support of our daily lives. Textbooks often list mineral resources and their uses, but usually neglect encouraging the understanding of our dependence upon them. This booklet is an attempt to fill that void. It was developed for teachers and students interested in exploring the role of minerals in our society, included are activities on the location, production and uses of mineral resources. The material can be used to stimulate discussion, enhance an existing program or help initiate the study of mineral resources. The concepts are not in a specific order nor does the information constitute a curriculum.

Educators interested in designing programs that recognize and address students' learning styles and thinking skills will find this a useful supplement. The activities encourage independent thinking and self-expression. Educators should not be critical of the students' drawings, but should encourage them to verbalize their perceptions. Stimulating creativity and the imagination will increase the potential for developing better problem solving skills in these future decision-makers. Educators are also encouraged to be innovative and design other imagination sheets.

The concepts and activities were developed by Donna L. T. Szuhly. Ms. Szuhly has been involved in formal and nonformal education for over 20 years. She has taught at the elementary, secondary and college levels. Her commitment to conservation and education has resulted in the development of programs and materials for students and teachers, as well as conservation organizations.

David O'Connor did the illustrations. Mr. O'Connor has been a layout artist and graphic designer for both educational and commercial publications since his graduation from the Columbus College of Art and Design in 1974.

This booklet has been published by Women In Mining Education Foundation; a nonprofit corporation dedicated to improving public understanding and awareness of the minerals resource industry. Persons interested in becoming more familiar with the educational materials and mineral activities available should contact the Women In Mining Education Foundation, P.O. Box 260246, Lakewood, CO 80226-0246 or through our Web-site at: [www.womeninmining.org](http://www.womeninmining.org). Educators are given permission to duplicate sheets or produce overhead projections for classroom use.

The authors and WIMEF appreciate the comments and suggestions made by these educators and students in Ohio and Indiana who utilized the activities in this publication.

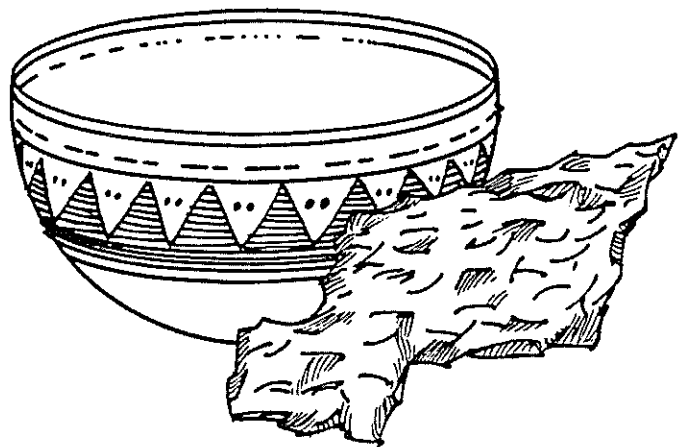

Early stone age men and women were miners. They used clay, flint and copper to make tools and utensils. Draw some modern appliances and equipment made from minerals.

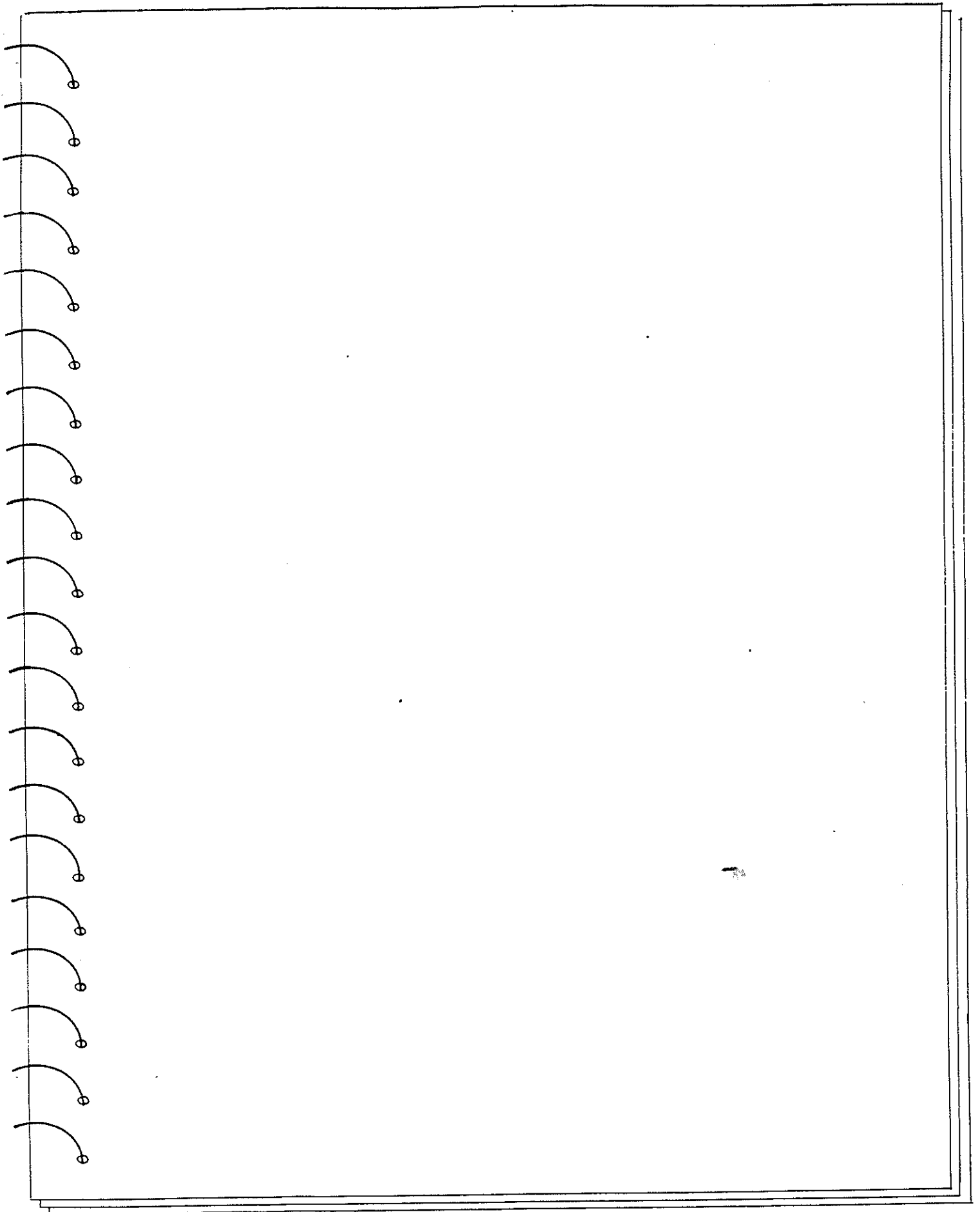

Mining has been important in everyone's past and is important to everyone's future. Salt, coal and iron ore helped in the growth and development of the United States. Show how one of these minerals was used in the past, is being used today, and might be used in the future.

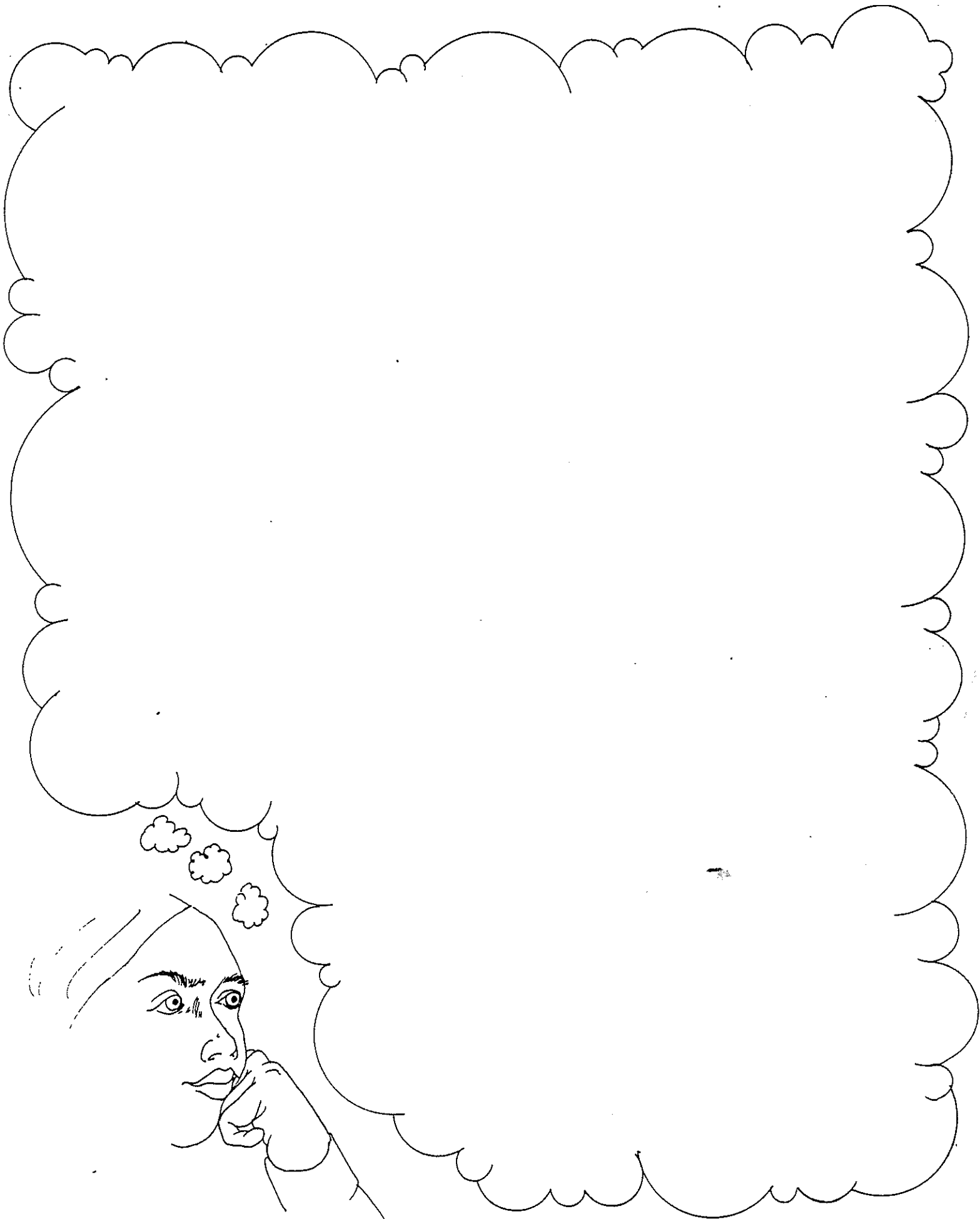

Minerals production uses the skills of many people and professions. The mining industry employs both men and women to work as mining engineers, truck drivers, welders, and computer operators. Show the job you would like to do

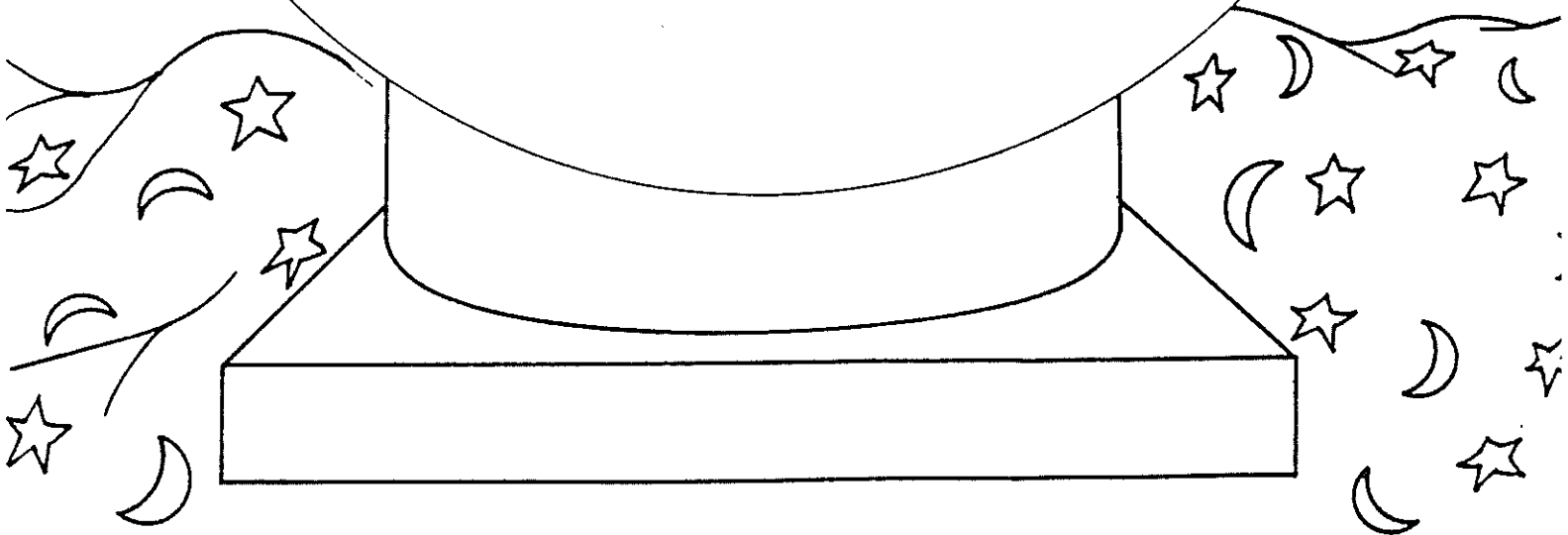
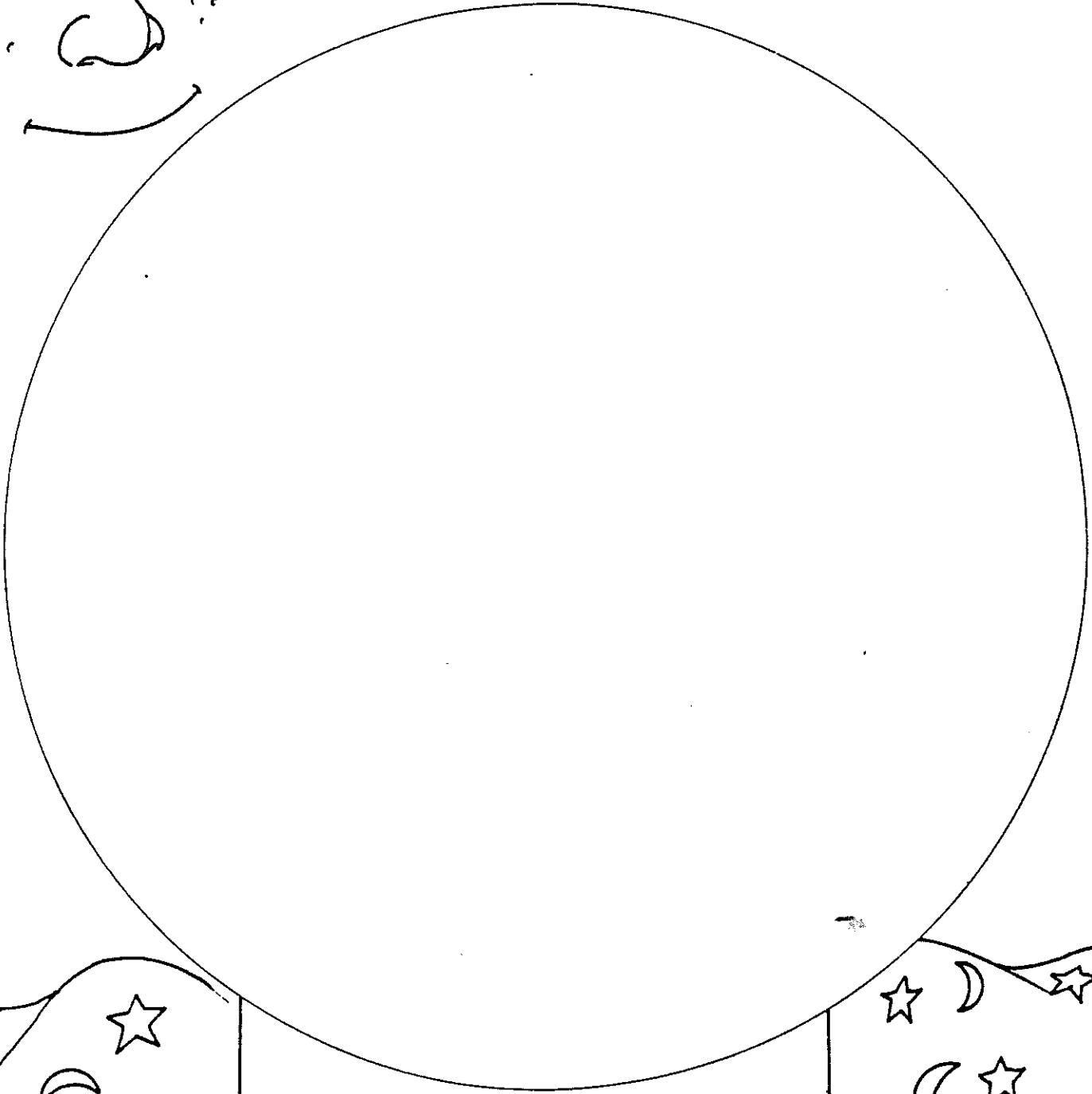
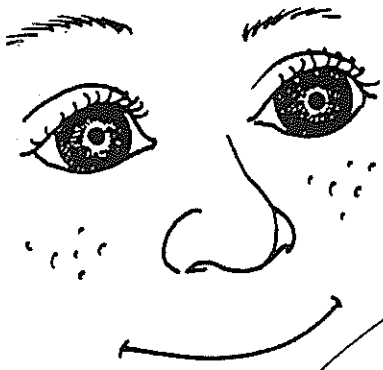

Sand and gravel deposits left by glaciers are important sources of minerals used in construction. The earth's crust contains the mineral wealth that was created during geologic history. Show the geological event you would like to see.

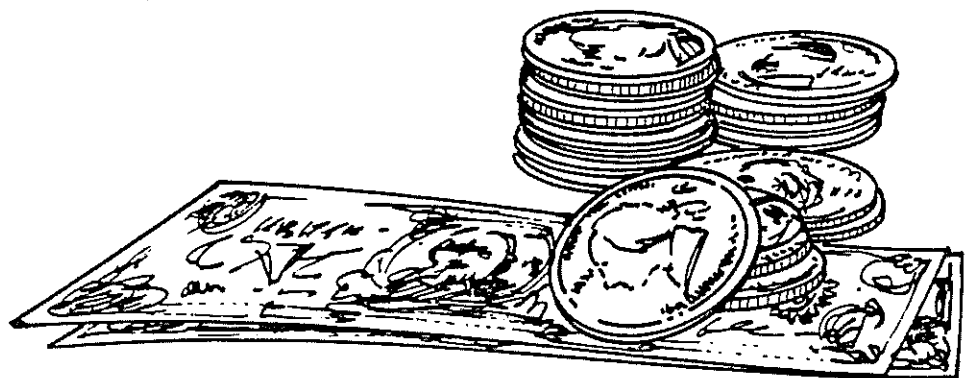

Before mining a mineral, it must be profitable to extract. Some costs in getting it to market include mining equipment, labor, transportation and taxes. Show what you would buy if you owned a profitable mining company.

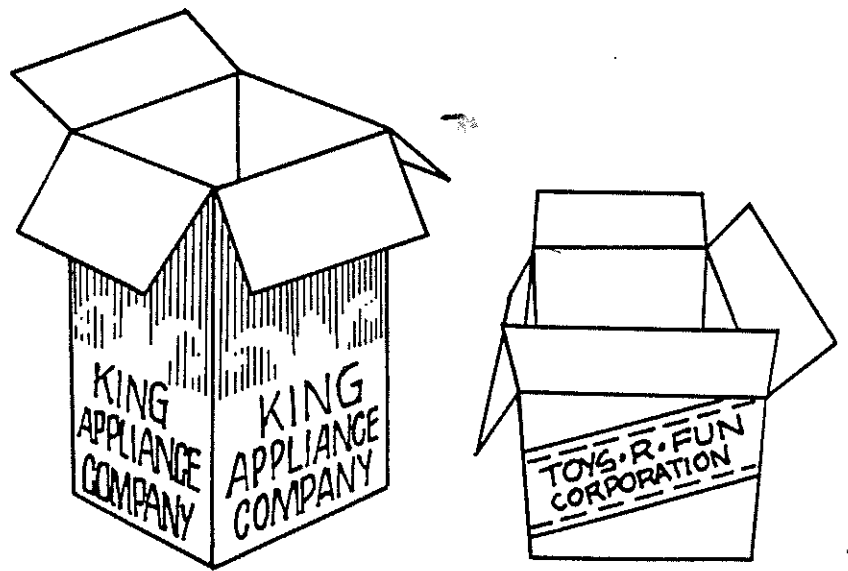

Metallic minerals, such as iron ore, become the basic material in many useful objects. After mining, the ores are smelted to produce a metal. Draw some of the things you own that are made of metal.

## MINING AND RECLAIMING A COOKIE

**OBJECTIVE:** Student will be able to identify some of the challenges associated with reclaiming land that has been mined.

**TIME:** Fifteen minutes

**THINKING SKILLS:** Classifying, Predicting, Inferring, Communicating

**TEACHER'S NOTE:** The following activity can be used to introduce students to the concept of reclamation and challenges associated with it. Choose chocolate chip or raisin cookies that have individual pieces so that the cookie can be completely mined. The following steps make this activity simple, fun and meaningful.

- ACTIVITY:**
- 1) Give each student two cookies, but tell them to work with only one during the first 10 minutes.
  - 2) Ask them to remove all the chocolate chips or raisins from the cookie and place the remains in a pile. Circulate among the students encouraging them to remove and eat all traces of chips or raisins.
  - 3) After they have "mined" the first cookie, ask them to rebuild it from the remaining pile. A few moans and groans along with some laughter will follow.
  - 4) After a couple of minutes have them compare their efforts with students nearby.
  - 5) List the difficulties they experienced on the board. Discuss how mining the land for minerals and building materials can alter the environment and present challenges for reclamation.
  - 6) Now have the students mine the second cookie and reclaim it. Discuss what they did differently to make reconstruction easier and return the cookie closer to the original.

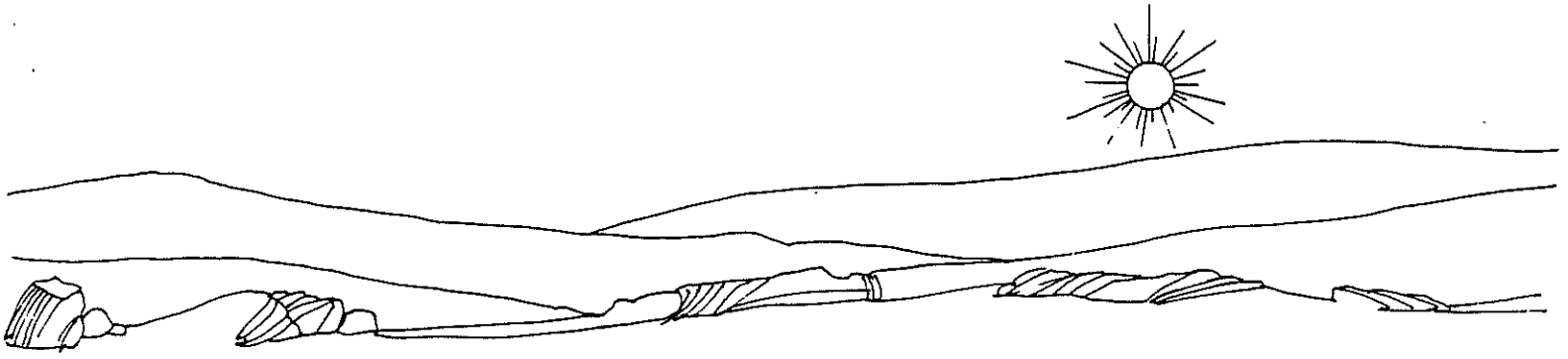

Mining is a temporary land use. It isn't finished until the land is reclaimed and returned to a usable condition. Show what you would do to make this land useful as a farm, nature area or

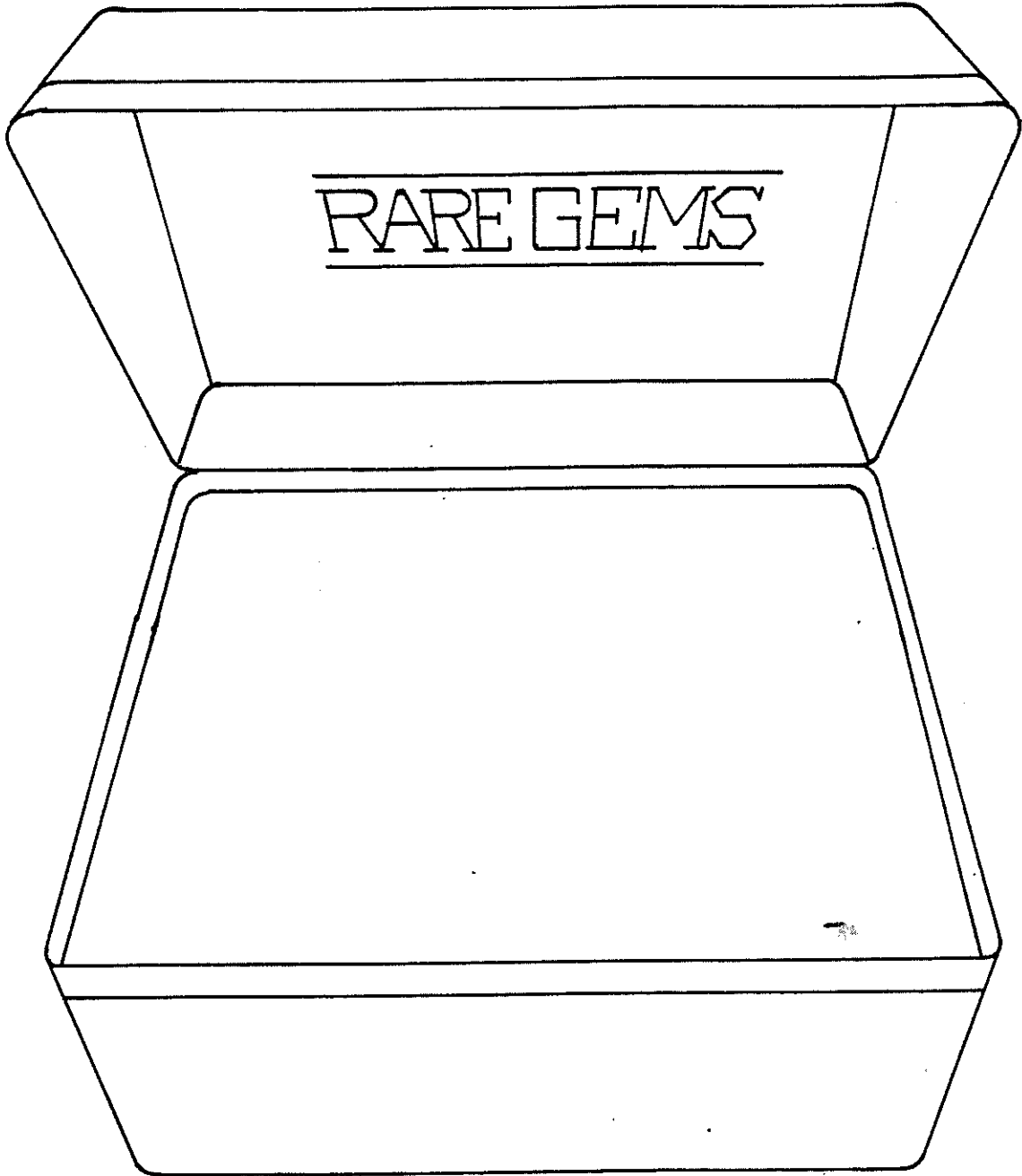

Many people dream of owning a gold mine. Silver, gold and platinum are rare and precious minerals. Draw an expensive piece of jewelry made from one of these limited minerals.

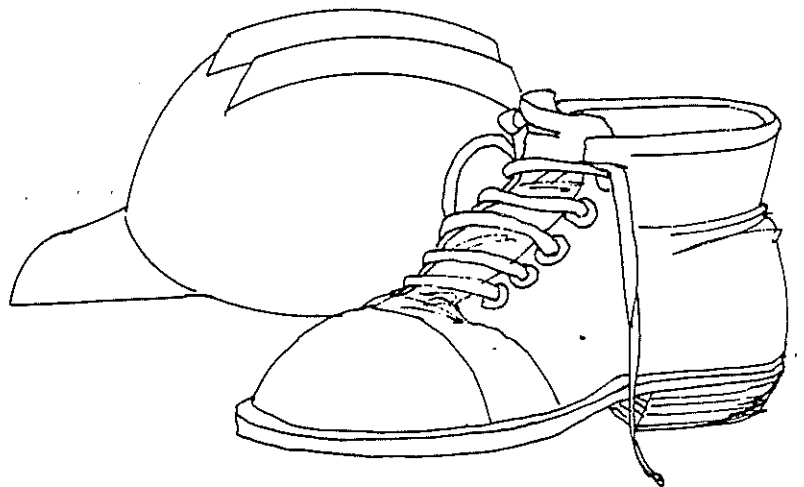

The earth is a minerals warehouse. The first step in mining the land is to dig a hole. Draw some tools and machinery you would use in mining.

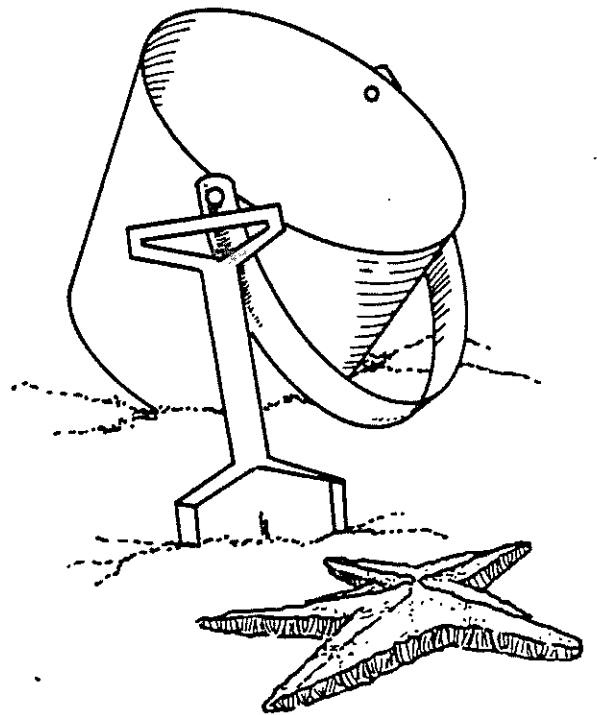

We are all miners, kids too. Raw materials mined are used to build many things. Design a sand castle you would build at the beach.

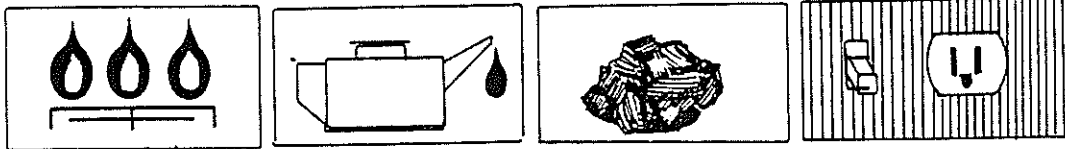

Gas, oil and coal are fossil fuels used to produce electricity. Modern appliances rely on energy to work. Draw something in your home that uses electricity.

## LOCATIONS OF MINERALS

**OBJECTIVE:** Students will be able to identify the location of major minerals.

**TIME:** Several Class Periods

**THINKING SKILLS:** Classifying, Communicating

**TEACHER'S NOTE:** The following activity can result in a meaningful bulletin board display. Less crowding and a more colorful map will result if a symbol is chosen to represent each mineral. This can be followed with a discussion of the historical developments in an area of world crisis.

**ACTIVITY:** Divide the 50 states or major countries among the students in the class. Have each student look up the important minerals produced in their assigned area. On a large plain map of the United States or the world have them list the mineral wealth. Students may be given the following list as a guide or it may be a check list after researching the states or countries.

### IMPORTANT MINERALS

#### Non-Metallic

Talc  
Mica  
Kaolinite  
Quartz  
Calcite  
Sulfur  
Halite  
Gypsum  
Fluorite  
Graphite  
Feldspar

#### Metallic

Gold  
Silver  
Iron  
Copper  
Lead  
Zinc  
Tin  
Aluminum  
Mercury  
Titanium  
Uranium

#### Fossil Fuels

Coal  
Oil  
Gas

#### Building Materials

Limestone  
Sandstone  
Granite  
Clay  
Marble  
Gravel  
Sand

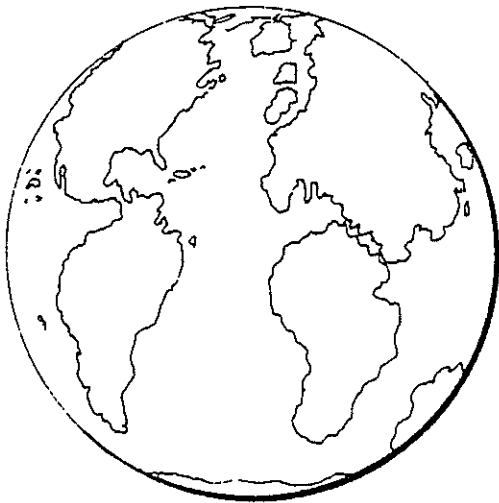

\* Miners must dig for minerals where they exist not where we wish them to be. Minerals must then be transported by truck, rail, ship or pipeline to areas where they will be used. Design a vehicle that can transport minerals.

## BUILDING WITH MINERALS

**OBJECTIVE:** Students will better understand the diversity and use of minerals in our modern society.

**TIME:** One Hour

**THINKING SKILLS:** Observing, Classifying, Interpreting Data

**TEACHER'S NOTE:** In this activity you may need the permission of the school principal and custodian to have students enter restricted areas.

**ACTIVITY:** In small groups, the students should examine both the inside and outside of the school building to find all the types of materials used in its construction. Have them list the item, material used and whether it is a metallic or a non-metallic mineral. Wood products should be listed separately. After the groups return to the classroom make a composite list. A discussion can follow to identify the type of mineral used.

### EXAMPLE LIST:

Item	Material	Metallic or Non-Metallic	Mineral Resource
door	aluminum	metal	bauxite
window	glass	non-metallic	silica

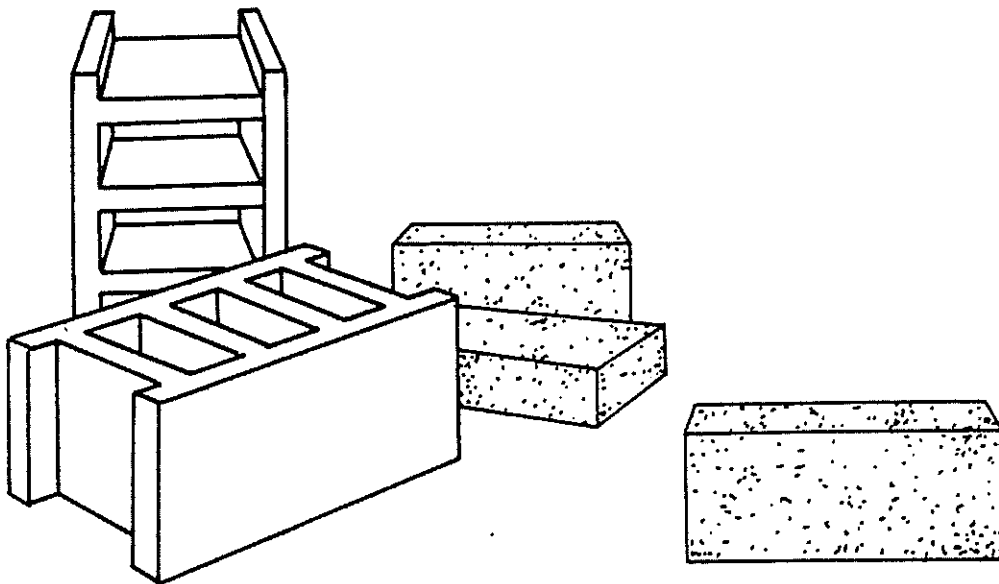

\* Limestone, sandstone and clay are non-metallic minerals. These are important in producing cement, bricks and other building materials. Design a city built with these resources.

## RENEWABLE / NONRENEWABLE / RECYCLABLE

**OBJECTIVE:** Students will better understand which resources are renewable, nonrenewable or recyclable.

**TIME:** One Hour

**THINKING SKILLS:** Classifying, Inferring, Communicating

**TEACHER'S NOTE:** This activity can involve a great amount of discussion, research and learning if the role of the sun, electricity and human energy is identified.

**ACTIVITY:** Consumers generate waste which is a potential source for other products. Have the class brainstorm a list of materials their families throw away or dispose of, that could be recycled to another use (i.e. paper, cans, garbage, clothing). Divide the class into small groups and have each group choose one item to trace back to the original source of minerals.

### EXAMPLE:

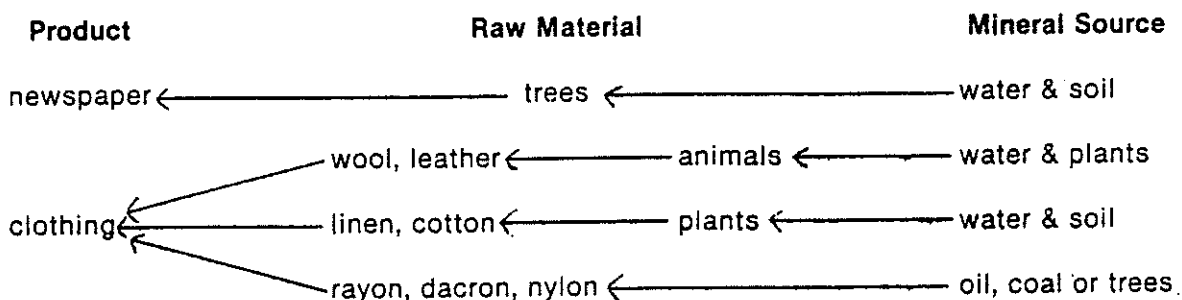



# YOUR FAMILY HERALD

1974 12 15 10 15 20 25 30 35 40 45 50 55 60 65 70 75 80 85 90 95 100

1974 12 15 10 15 20 25 30 35 40 45 50 55 60 65 70 75 80 85 90 95 100

VOL. XXXVII

NOVEMBER

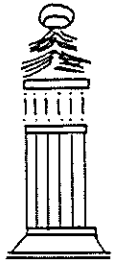

## PHOTO REVEALS New Spacecraft

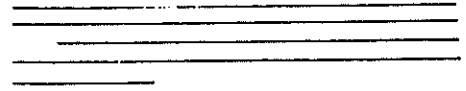
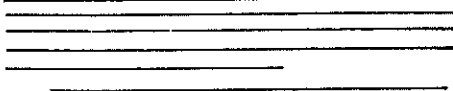
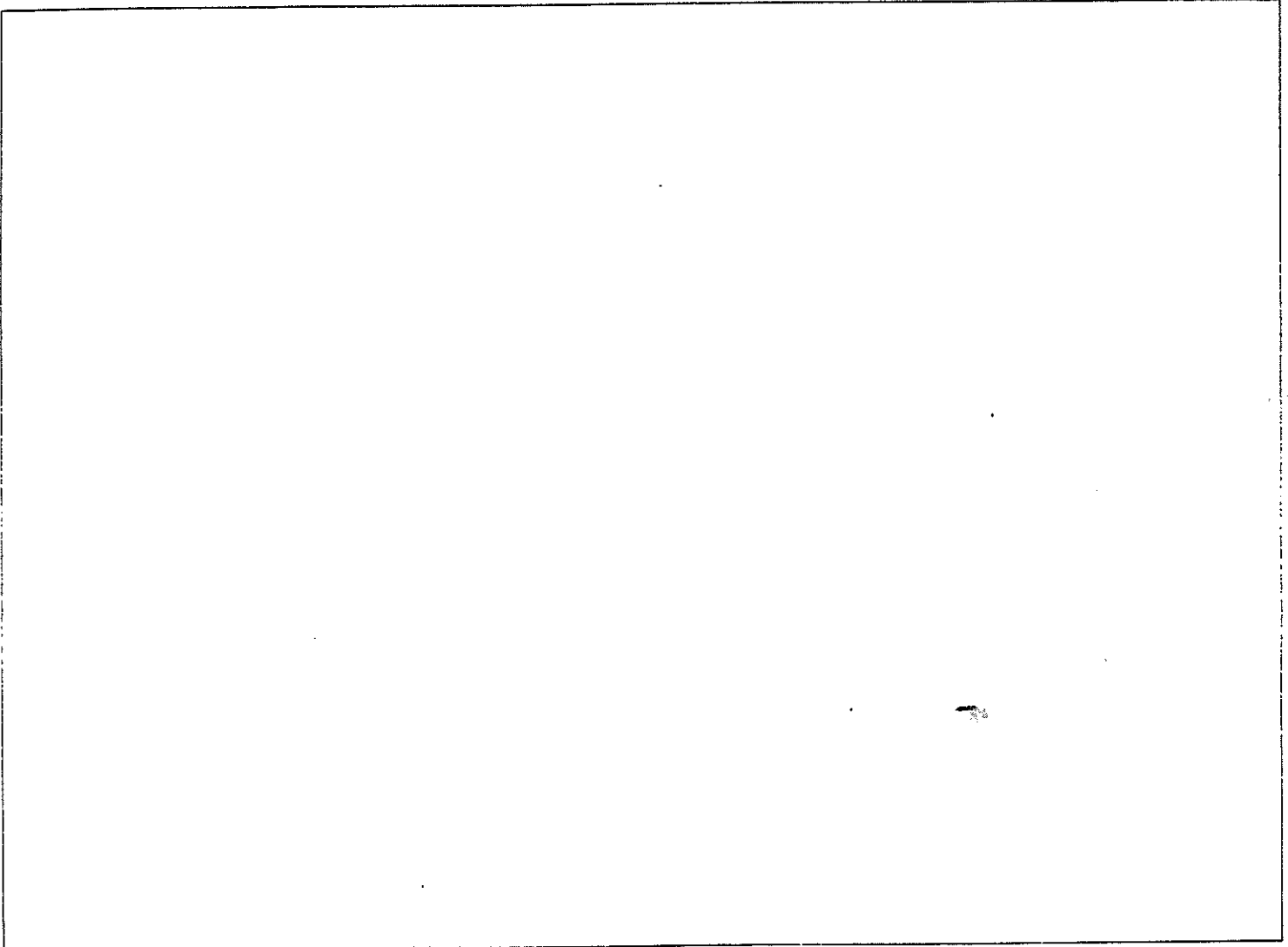
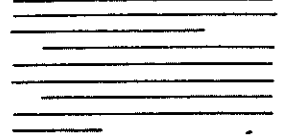
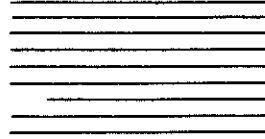

\* Minerals are a non-renewable resource. The waste by-products left by today's miners represent future sources of minerals. Design a space craft that could be built by reprocessing today's wastes.